



PT GROWTH SUMATRA INDUSTRY

INDONESIA

MILL TEST CERTIFICATE

CUSTOMER :

COMMODITY : COLD DRAWN STEEL WOUND BARS

CERTIFICATE NO : 403/07/091/2013

SPECIFICATION : S20 404 - B - III

NO. 10

DATE OF ISSUE : 28/09/2014

No. Contract : -

DIMENSION DIANGKUP LENGKAP (10, mm)	HEAT NUMBER	QUANTITY	CHEMICAL COMPOSITION (%)					TENSILE STRENGTH (N/mm ²)		HARDNESS	
			C	Si	Mn	P	S	(Rm)	(ReL)	(HRC)	(HB)
2 In 6	1048E	300	0.1871	0.206P	0.5115	0.0269	0.0263	627	-	-	174

Approved by :

Manager of Quality Control Department

[Signature]
PT Growth Sumatra Industry
SUMATERA UTARA

Ir. HENDRI SP. Mardilang

Prepared by :

[Signature]

usha siam

FORM No. : F-QP-2-13.02
REV. : 11
DATE : 28.05.2016

Usha Siam Steel Industries Public Company Limited

Factory: 101/46, Moo 20, Navanokorn Industrial Estate, Klongnueng Klongluang Pathumthani 12120 Thailand

Phone : (662) 529-1088, 529-1167-8, Fax (662) 529-0418, www.ushasiam.com

CERTIFICATE OF TEST

Customer Order Ref. WTS2/1718-0034 (INDO) Certificate No. E-1819-0739
Works Order Ref. 222347 Date 02.07.2018
Reel / Coil No. WTS2/1718-0034/1 Invoice No. SLE/38000175
Length of Reel / Coil 1x2000 Mtrs. Net Weight 0.824 Mt.
Party's Name and Address PT.Usha Martin Indonesia

Type of Product : STEEL WIRE ROPE

This is to certify that the material described below conform to : API SPEC 9A : 2011/CUSTOMER SPEC

Test Results

Test Items	Specification	Test Results
Diameter	10.00 mm. (+5/-0%)	10.12-10.30 mm.
Construction	6x36WS	6x36WS
Lay Direction	RHOL	RHOL
Lay length	72.50 mm.Max.	64.80 mm.
Core	IWRC	IWRC
Tensile Strength	1960 N/mm ²	1960 N/mm ²
Type of Coating	GALVANIZED	GALVANIZED
Type of Lubrication	A2	A2
Minimum Breaking Load	69.80 kN.	76.40 kN.
Date of Sample Testing		02.07.2018

Certify that above information is in accordance with the records of the company and conforms the specification (s) as stated.

Certify Authority

Manager Quality Assurance

Usha Siam Steel Industries Public Company Limited



[Handwritten Signature]
Signature: *[Handwritten Signature]*
No: 3520996

DNV-GL



Usha Siam Steel Industries
Public Company Limited



PT. SUPRA TALINDO

Jl. Danau Agung 1 Blok A 4 No. 16, Jakarta – 14350 Indonesia
Telp: 021-64711272, 6459248-9 Fax: 021-64712622, 6513739
Email : marketing@supratalindo.co.id

CERTIFICATE OF PERFORMANCE-VISUAL EXAMINATION
"OFFSHORE CONTAINERS AND ASSOCIATED LIFTING SETS PART2: LIFTING SETS - DESIGN
MANUFACTURING AND MARKING"

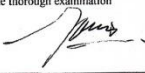
Certificate Number :			
Name of Customer :			
Customer Ref. :			
Description of Wire Rope 10mm,6x36 IWRC RHOL 1960 N/mm Galv, MBF : 69.80 kN c/w ABS Statement of Compliance No.BG3620976-031 Date of Fabrication : 02.07.2018 Manufacture by : Usha Siam Rope Number : WTS2/1718-0034/1 Certificate Number : E-1819-0739		Description of Accessories 2ea Crosby Cold Tuff standard sleeve S-505 3/8", Pic : STK 1ea Thimble hd 3/8".	
Distinguishing Number of Mark	Description of Gear	Quantity	Working Load Limit
ST 621 WLL 1,3 T	steel wire rope Flemish eye secured with mech splicing system soft eye one end thimble eye other end with crosby steel ferrule S-505. E : 15cm Diameter : 10mm Length : 99 Cm	1ea	Single Leg  1,3 ton
According To General Purpose wire rope sling-BS EN 13414-1:2003/A:2005(E)			
Other Information Our load cell for proof loader is calibrated by Balai Besar Teknologi Kekuatan Struktur (BPPT) Serial Number : 5926.1786.2010		Name and Position of person who carried out the thorough examination  Inspector : Norman Kosasih Date of issue : 28 September 2018	

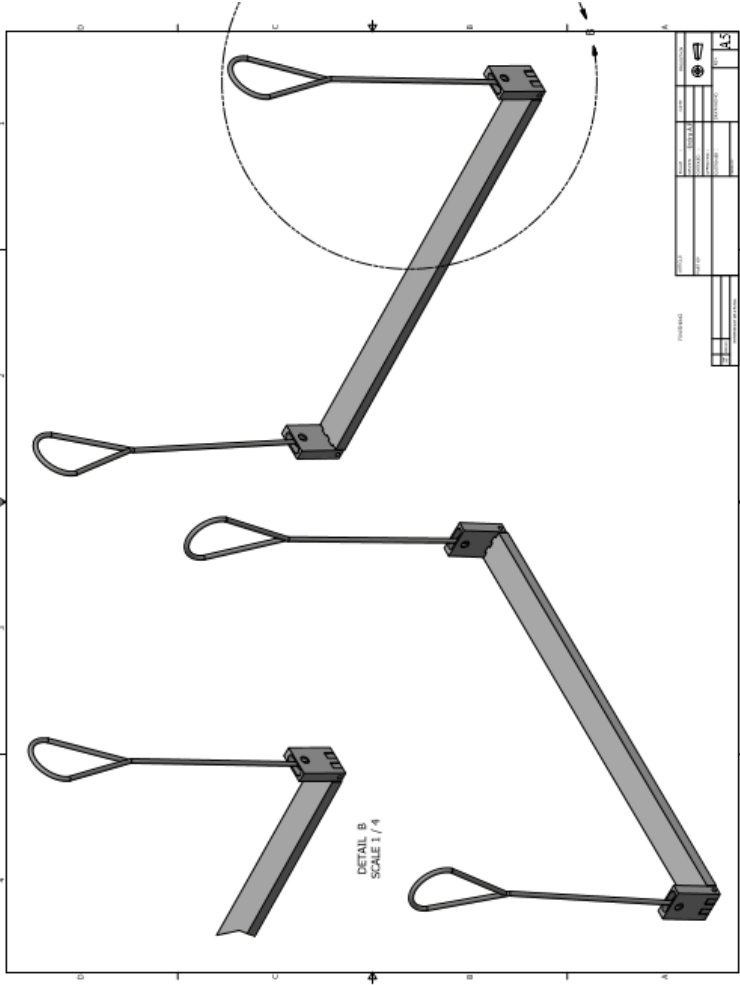

REV	DATE	BY	CHKD	APP'D
1				
PROJECT NAME				
DRAWING TITLE				
SCALE				
SHEET NO.				
TOTAL SHEETS				
DESIGNED BY				
CHECKED BY				
APPROVED BY				
DATE				

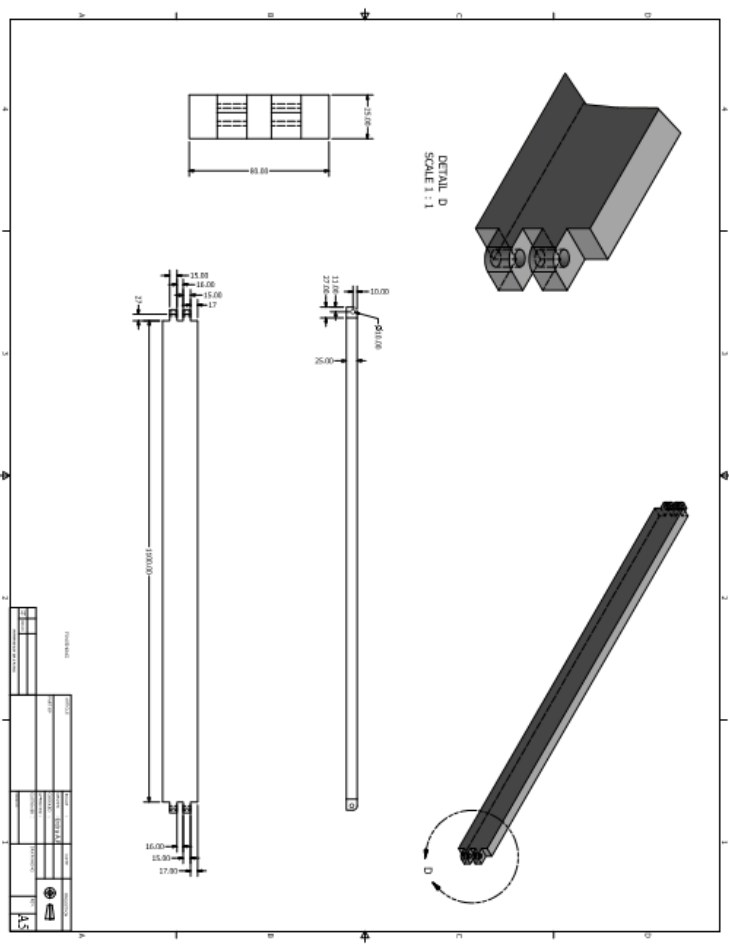

DETAIL D
 SCALE 1:1

1. TITLE 2. DATE 3. DRAWN BY 4. CHECKED BY 5. APPROVED BY	
6. PART NAME 7. QUANTITY 8. MATERIAL 9. FINISH 10. TOLERANCES 11. DIMENSIONS 12. NOTES	
13. SCALE 14. SHEET NO. 45	

