

## LAMPIRAN

### Lampiran 4.1

Data parkir apartemen metropolis				
waktu	mobil		motor	
	masuk	keluar	masuk	keluar
06.00-07.00	16	26	6	6
07-00-08.00	22	48	7	6
08.00-09.00	26	28	23	12
09.00-10.00	33	13	21	14
10.00-11.00	39	14	14	13
11.00-12.00	45	17	10	14
12.00-13.00	29	35	18	18
13.00-14.00	32	16	16	21
14.00-15.00	40	40	18	11
15.00-16.00	38	28	20	18
16.00-17.00	37	24	16	20
17.00-18.00	35	51	22	23
18.00-19.00	28	19	22	19
19.00-20.00	35	16	17	17
20.00-21.00	27	11	16	15
21.00-22.00	13	15	9	15
jumlah	495	401	255	242

Lampiran 4.2

Data luasan apartemen metropolis									
no	type	luasan/unit	Jumlah unit/lantai	jumlah lantai	jumlah unit	luas total m2	total jumlah kamar		
<b>TOWER A</b>									
1	Studio	20,91	5	1	5	104,55	5		
2	Studio	20,91	9	14	126	2634,66	126		
3	1 BR	28	6	14	84	2352	84		
4	2 BRA	43,19	1	14	14	604,66	28		
<b>TOWER B</b>									
1	studio	20,91	8	14	112	2341,92	112		
2	1 BR	28	6	14	84	2352	84		
3	2 BRA	43,19	1	14	14	604,66	28		
4	2 BRC	42,08	1	14	14	589,12	28		
<b>TOWER C</b>									
1	studio	20,91	13	15	195	4077,45	195		
2	1 BR	28	6	15	90	2520	90		
3	2 BRA	43,19	2	15	30	1295,7	60		
<b>TOWER D</b>									
1	Studio	20,91	6	1	6	125,46	6		
2	1 BR	28	6	1	6	168	6		
3	2 BRA	43,19		1					
4	2 BRC	42,08	4	1	4	168,32	8		
5	BR PENHOUSE	62,73	3	1	3	188,19	9		
<b>LUAS TOTAL EFEKTIF</b>						<b>787</b>	<b>20126,69</b>	<b>869</b>	

Lampiran 4.3  
Gambar Eksisting denah parkir

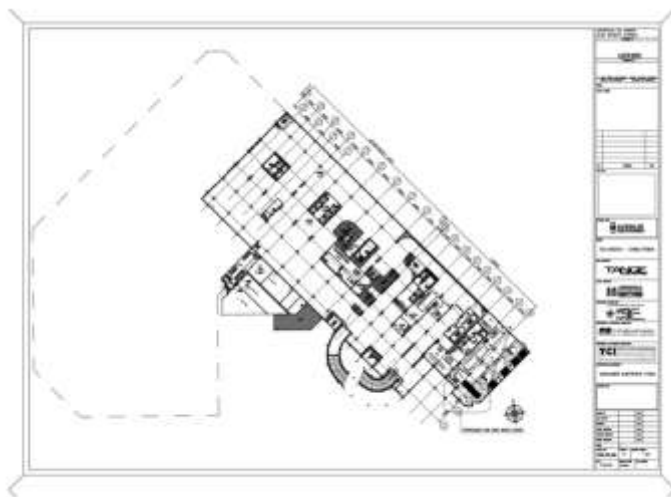

Gambar eksisting lantai basement

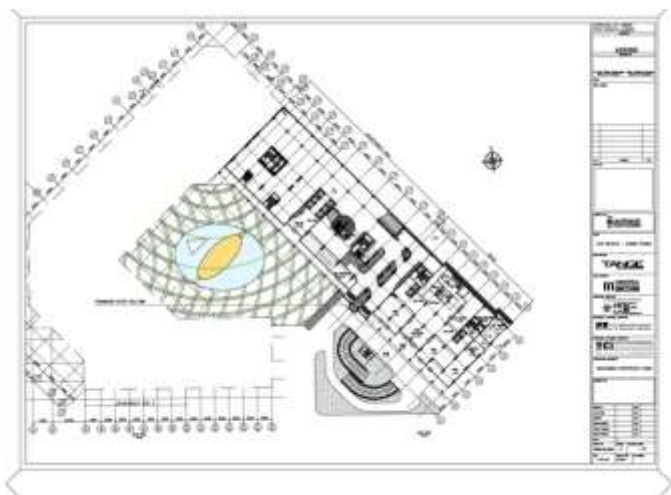

Gambar eksisting lantai dasar

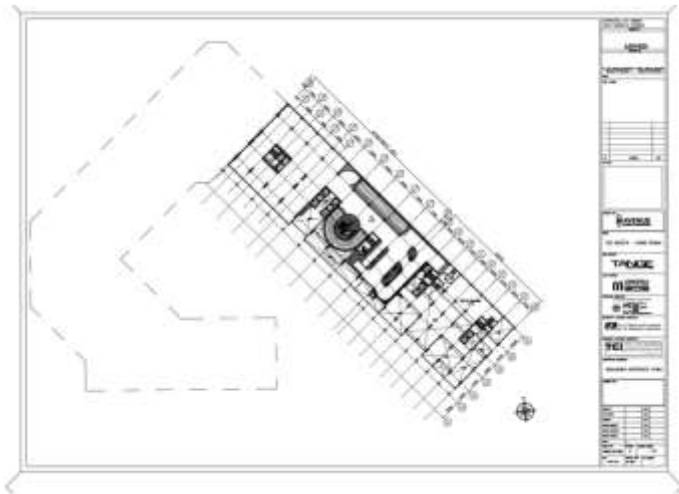

Gambar eksisting lantai 1

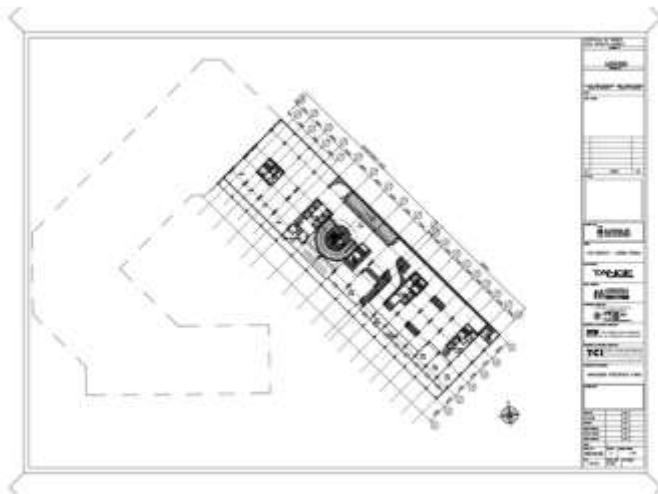

Gambar eksisting lantai 2

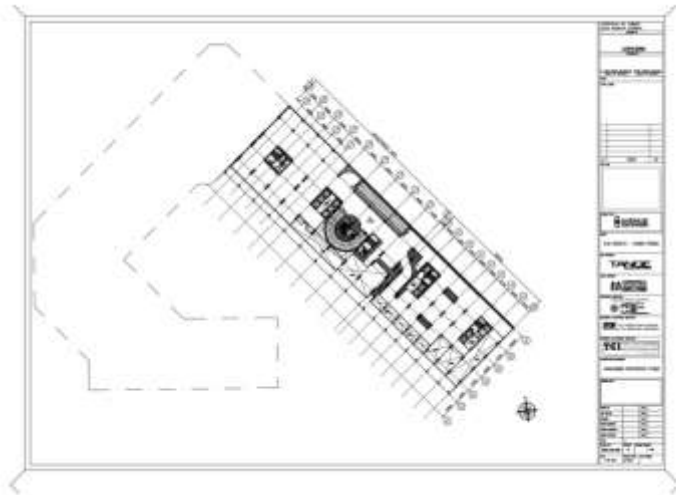

Gambar eksisting lantai 3

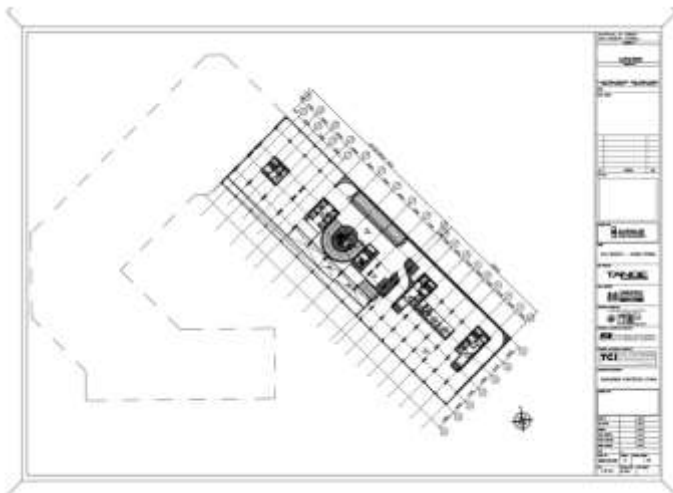

Gambar eksisting lantai 4

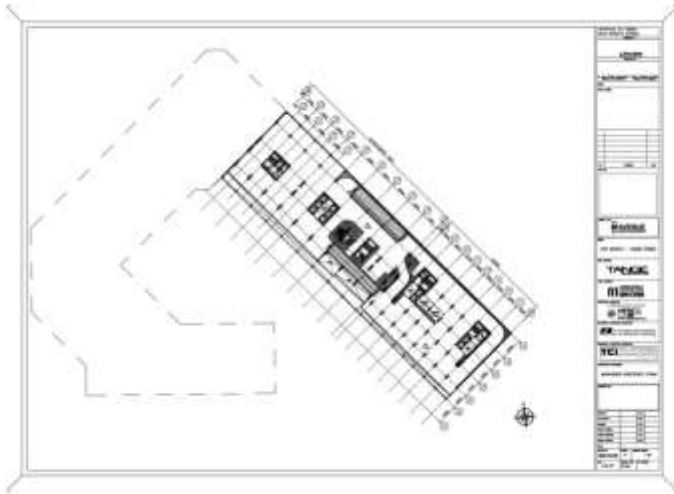

Gambar eksisting lantai 5

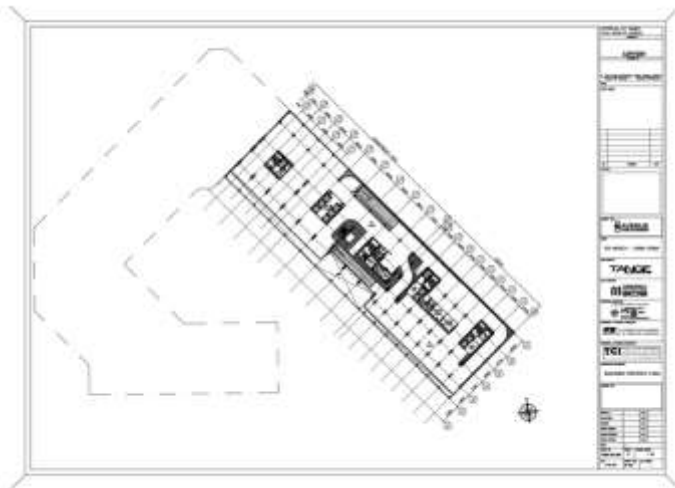

Gambar eksisting lantai 6

Lampiran 4.4  
Gambar Rencana denah, tata letak dan sirkulasi parkir

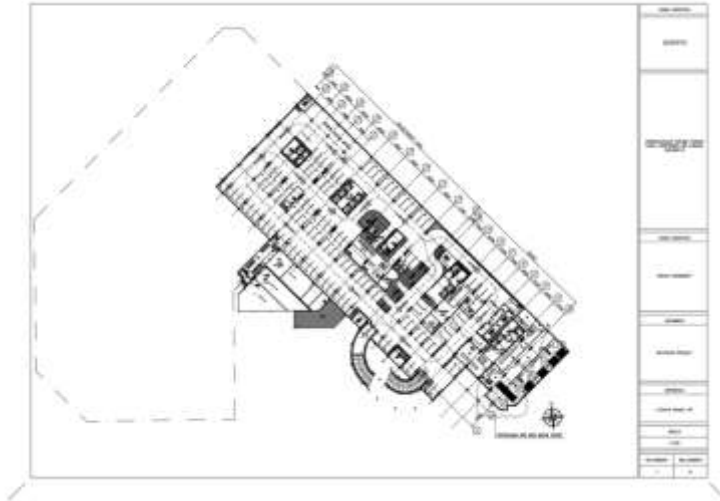

Gambar Rencana lantai basement

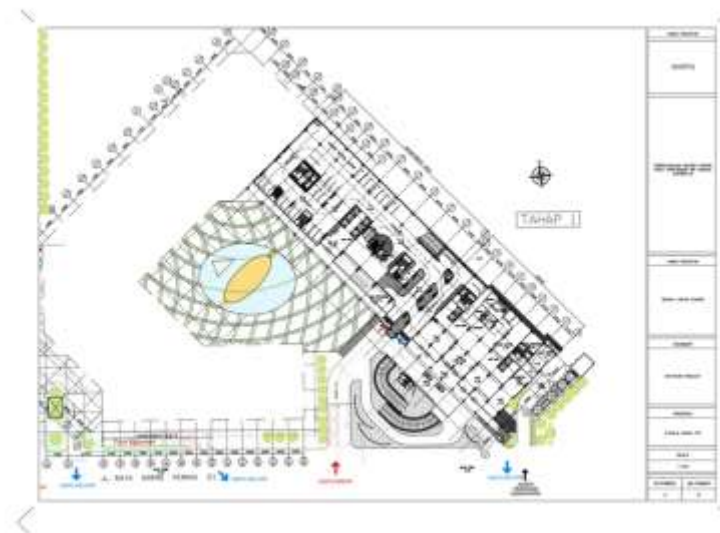

Gambar Rencana lantai dasar

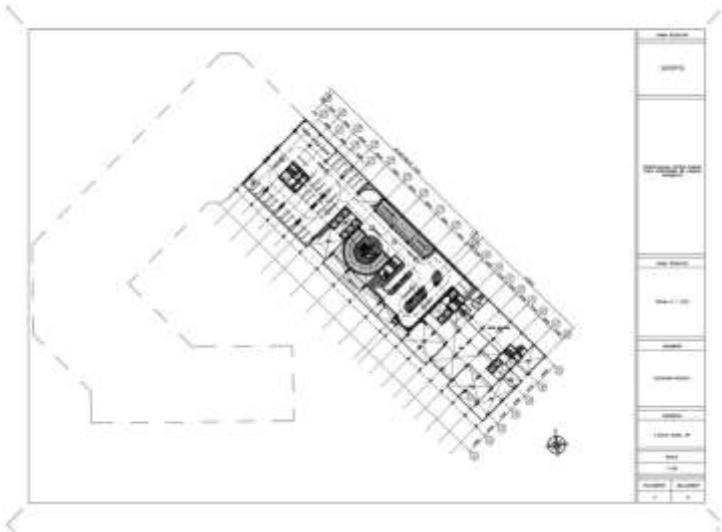

Gambar Rencana lantai 1

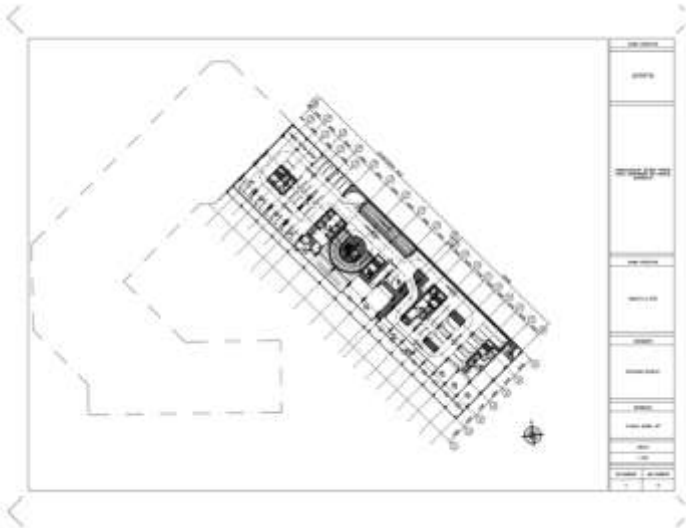

Gambar Rencana lantai 2



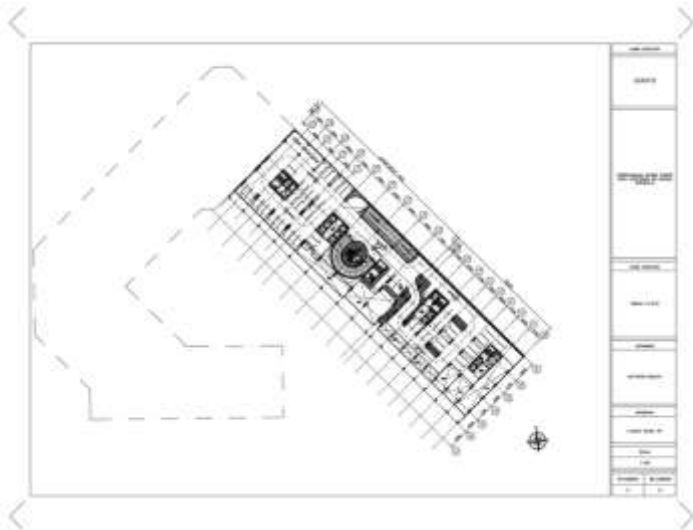

Gambar Rencana lantai 3

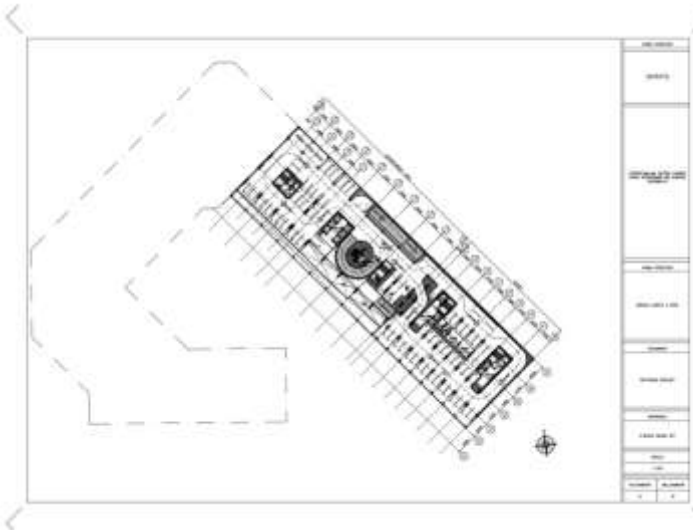

Gambar Rencana lantai 4

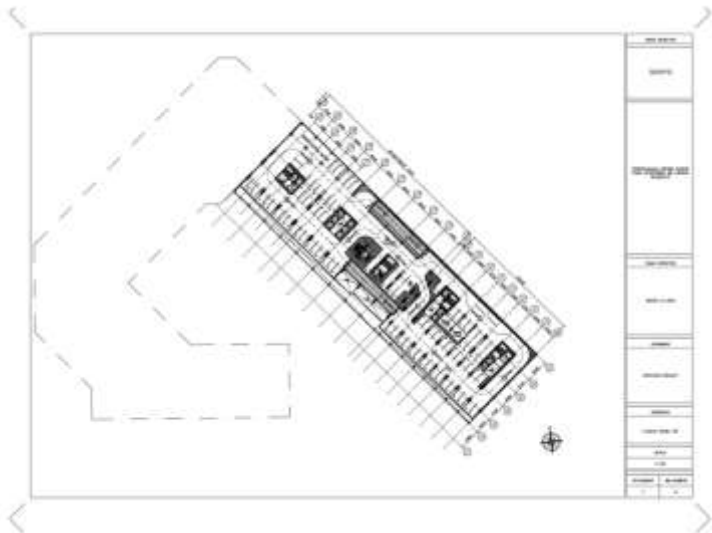

Gambar Rencana lantai 5

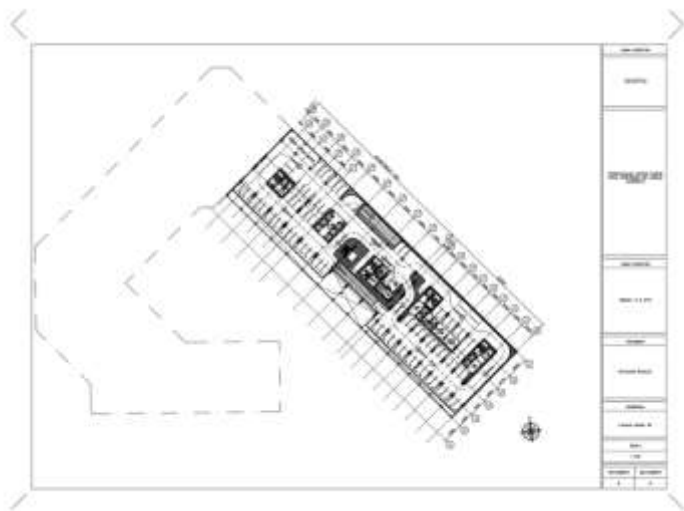

Gambar Rencana lantai 6

Lampiran 4.5  
Lembar Asistensi



**UNIVERSITAS MUHAMMADIYAH SURABAYA**  
**FAKULTAS TEKNIK**  
**PROGRAM STUDI S-1 TEKNIK MESIN, S-1 TEKNIK ARSITEKTUR, S-1 TEKNIK SIPIL,**  
**S-1 TEKNIK PERKAPALAN, S-1 TEKNIK ELEKTRO, D-3 TEKNIK KOMPUTER**  
 Alamat : Jalan Satorejo 59 Surabaya  
 Telp./Fas. 031-3811966 ext.138

---

**CATATAN BIMBINGAN SKRIPSI**

**FORM S-10**

Nama : Oktavia Fitrialdi  
 NIM : 20151333052  
 Judul Skripsi : Perencanaan Sistem Purifikasi pada Apartemen 38 Avenue Surabaya  
 Pembimbing Utama : Ir. Samiuddin, M.T.  
 Pembimbing Pendamping : M. Fatchu Huda, S.Pd., M.T.  
 Tgl. Mulai Bimbingan : 19 Januari 2020

No.	Tgl	Materi	Paraf Pembimbing		Paraf Mahasiswa
			U*	P**	
1	10/1/20	- Cari jumlah kamar/unit untuk hotel dan apartemen - Cari luas bangunan untuk perbandingan - Cari jumlah kendaraan parkir			
2	31/1/20	- Jika kesulitan data, cari data di apartemen lain			
3	10/2/20	- Perbaikan penulisan bab 1-4			
4	28/2/20	- Perbaikan penulisan - Kertas baru pada bab 4			
5	23/3/20	- Perbaikan bab 4 - Perbaikan bab 1-3			
6	25/10/20	- Perbaikan bab 4 - Perbaikan penulisan bab 1-5 - Melengkapi bab 4 dan 5			
7	02/11/20	- Melengkapi siklus BPR dan wawancara ke Apartemen Studi - Perbaikan draft dan abstrak			



UNIVERSITAS MUHAMMADIYAH SURABAYA  
FAKULTAS TEKNIK  
PROGRAM STUDI S-1 TEKNIK MESIN, S-1 TEKNIK ARSITEKTUR, S-1 TEKNIK SIPIL,  
S-1 TEKNIK PERKAPALAN, S-1 TEKNIK ELEKTRO, D-3 TEKNIK KOMPUTER  
Alamat : Jalan Sarungay 39 Surabaya  
Telp./Fax. 031-3811966 ext.138

No.	Tgl	Materi	Paraf Pembimbing		Paraf Mahasiswa
			U*	**P	

Catatan:  
\*U artinya Utama dan \*\*P artinya Pendamping

Berhingga dinyatakan selesai

Surabaya, 06 NOVENBER 2014

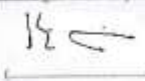
Pembimbing Utama Ditandatangani ketika skripsi tuntas 	Pembimbing Pendamping Ditandatangani ketika skripsi tuntas 
--	---

## BIOGRAFI PENULIS



**Oktavian Rizaldy**, lahir di Surabaya, 21 Oktober 1996 merupakan anak dari ayah Hery Herawadi dan Ibu Trisniati. Penulis telah menempuh Pendidikan formal di SDN Kedungdoro III/308 Surabaya (lulus tahun 2008), SMP Negeri 1 Wates Kabupaten Kediri (lulus tahun 2011), SMK Kartanegara Wates Kabupaten Kediri (lulus tahun 2014).

Pada tahun 2015, penulis melanjutkan studi Program Sarjana di Program Studi Teknik Sipil Universitas Muhammadiyah Surabaya. Penulis memiliki pengalaman kerja sebagai Surveyor di PT. Duta Segara Wisesa Mulai Maret 2017 hingga sekarang.

Email: [oktalevine@gmail.com](mailto:oktalevine@gmail.com)